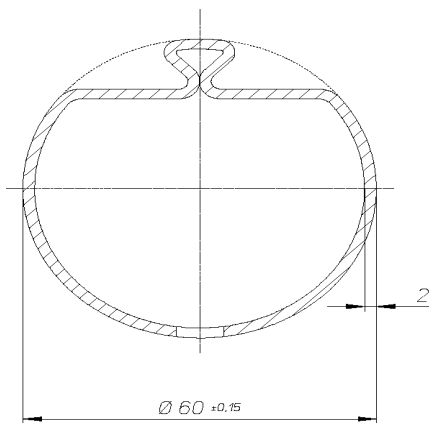
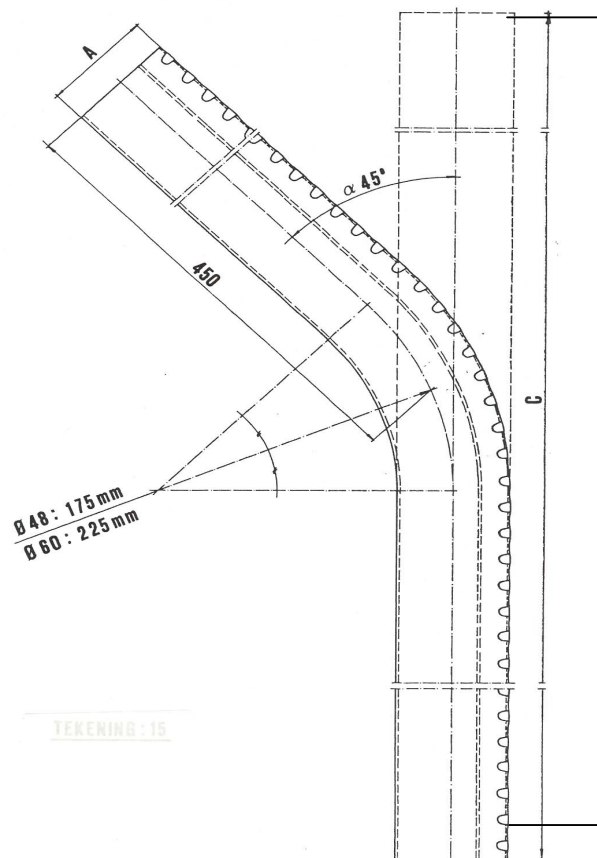

Bekaclip® Post**1. Scope**

The Bekaclip® post is made out of continuously hot-dip zinc coated steel sheet (Sendzimir) and subsequently polyester coated see fig 1 and photo 1 and 2 below.

There are two options: straight Bekaclip® post or Bekaclip® post with bent arm fig. 2 (extension bent at an angle from the vertical)

**Fig 1****Fig. 2**

Bekaclip® Post**1.1 Normative references**

- EN10326: Continuously hot-dip coated strip and sheet of structural steels – Technical delivery conditions.
- EN10327: Continuously hot-dip coated strip and sheet of low carbon steels for cold forming – Technical delivery conditions.
- EN13438: Powder organic coatings for galvanized steel products for construction purposes.

2. Raw material**2.1 Base Steel**

Chemical composition :

see table 1

Table 1 chemical composition	
Element	%
C	≤ 0,20
Si	max. 0.60%
Mn	max. 1.70%
P	max. 0.10
S	max. 0,045

The steel is in accordance with the European Standard EN10326. The designation of the steel is: S250. The steel strip is continuously hot-dip galvanized, in accordance with EN10326 Z275.

If DX51D quality is used in accordance to EN 10327, the yield strength shall be minimum 235N/mm².

2.2 Polyester Coating

The polyester is free of lead and cadmium

3. Requirements

Bekaclip® Post

3.1 designation

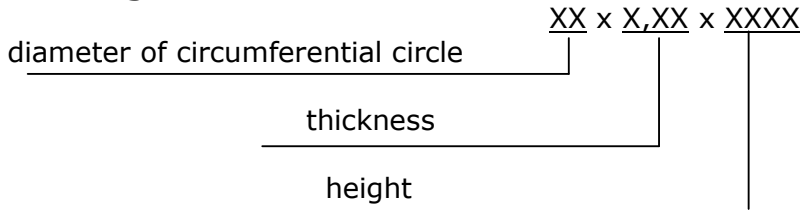

3.2 Dimensions and tolerances

diameter of the circumferential circle, thickness and height of the post : see table below

Straight Bekaclip® post table 2

diameter circumferential circle mm	44± 0,15(1)	48± 0,15(2)	60± 0,15	70± 0,15
thickness mm	1,00± 0,10	1,50± 0,15	2,00± 0,20	2,00± 0,20
Height mm				
1500±5	X	X	-	-
1700±5	X	X	-	-
2000±5	X	X	-	-
2300± 7,5	-	X	X	-
2500± 7,5	-	X	X	-
2700± 7,5	-	X	X	X
3000± 7,5	-	X	X	-
3500± 7,5	-	-	X	-

(1) actual 42,7 mm

(2) actual 47,6mm

X means stock product

Bekaclip® post with bent arm: table 3

diameter circumferential circle mm	48± 0,15(2)	60± 0,15
thickness mm	1,50± 0,15	2,00± 0,20
Height C mm (1)		
3100± 7,5	X	-
3250± 7,5	-	X
3600± 7,5	-	X

(1) is the height of the corresponding straight Bekaclip® post

(2) actual : 47,6

Bekaclip® Post**3.3 Tensile strength**

The strength is specified by
tensile strength: min. 300 N/mm²
yield strength: min. 235 N/mm²

3.4 Zinc

Zinc coating: Min. of 275 g/m² as an average of 3 measurements and doubleside determined in accordance with EN10326. (Z275)

3.5 Polyester coating**3.5.1 Colour**

Standard colour is green RAL 6005. Other standard colours are available and can be found in the technical data sheet TDS-99-33. (polyester coating)

3.5.2. Thickness of the coating

Minimum 60 µm, very locally the thickness can be 10% below this minimum

3.5.3 Adhesion

Make two scratches by means of a hard metal pointed graving tool through the coating and intersecting at an angle of 30° ± 5°. Lift a 30° peak with the point of the knife.
The coating shall not be able to be lifted from the metal by more than 5 mm.
The adhesion test and requirement are in accordance with the European Standard EN 10223-7

3.5.4 Resistance of the polyester to salt spray

make a rectangular diagonal cross by means of a hard metal pointed graving tool, penetrating through the metal. Test in accordance with ISO 9227 (neutral salt spray). After 1000 h there shall be no corrosion beneath the polyester or loss of adhesion in excess of 10 mm from the diagonals and no signs of blistering, cracking or crazing on any part of the specimen.

4. Cap

Each is provided with a cap out of UV resistant plastic.

Bekaclip® Post

5. Packaging

The Bekaclip® post will be put on a four way pallet.
 UV resistible shrinkfoil shall be used around each pack of posts.
 Each pack of posts shall have it's own Betafence label.
 Around the pallet there shall be UV resistible shrink or stretchfoil present.
 Two strong straps shall be used around the pallet.
 An identification label with the SAP-code and number of posts shall be put on each side of the pallet.

Table 3: Form of delivery and packing (Bekaclip® post without bent arm)

Diameter + thickness mm	Height of the post cm	Packed per	Number packs per layer	Number of layers per pallet	Number of posts per pallet	Dimensions of the pallet L x W x H Cm	Weight of the post Kg
44 x 1,00	150	5	7	5	175	160 x 105 x 71	1,85
44 x 1,00	170	5	7	5	175	180 x 105 x 71	2,09
44 x 1,00	200	5	7	5	175	210 x 105 x 71	2,46
48 x 1,50	150	5	7	5	175	160 x 105 x 75	2,96
48 x 1,50	170	5	7	5	175	180 x 105 x 75	3,35
48 x 1,50	200	5	7	5	175	210 x 105 x 75	3,95
48 x 1,50	230	5	7	5	175	240 x 105 x 75	4,54
48 x 1,50	250	5	7	5	175	260 x 105 x 75	4,93
48 x 1,50	270	5	7	5	175	280 x 105 x 75	5,33
48 x 1,50	300	2	10	7	140	310 x 105 x 75	5,92
60 x 2,00	230	2	8	6	96	240 x 105 x 65	7,35
60 x 2,00	250	2	8	6	96	260 x 105 x 65	8,00
60 x 2,00	270	2	8	6	96	280 x 105 x 65	8,63
60 x 2,00	300	2	8	6	96	310 x 105 x 65	9,60
60 x 2,00	350	2	8	6	96	360 x 105 x 65	11,20
70 x 2,00	270	1	12	6	72	280 x 105 x 71	9,76

Bekaclip® Post**Table 3: Form of delivery and packing (Bekaclip® post with bent arm)**

Diameter + thickness mm	Height of the post cm	Packed per	Number packs per layer	Number of layers per pallet	Number of posts per pallet	Dimensions of the pallet L x W x H Cm	Weight of the post Kg
48 x 1,50	310	2	10	6	120	325 x 105 x 58	6,11
60 x 2,00	325	2	8	5	80	340 x 105 x 58	10,40
60 x 2,00	360	2	8	5	80	375 x 105 x 58	11,53